

Transistors as Switches

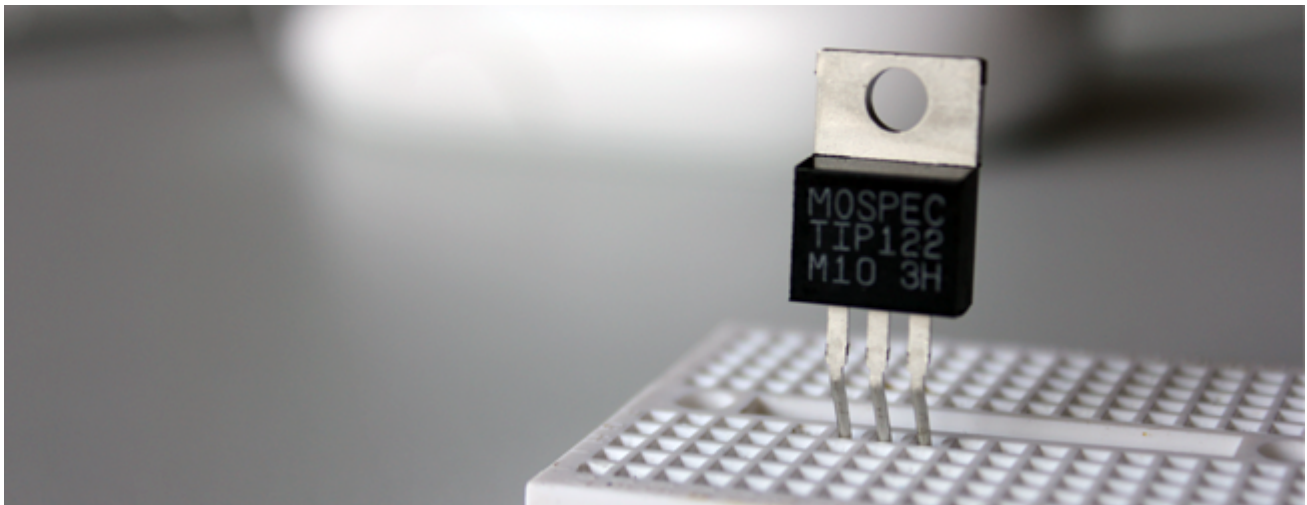

When we talk about “transistors”, we usually mean a bipolar transistor. Transistors consist of semiconductors, which means they can transition from conducting to non-conducting. These properties can be used as a kind of electrically activated “switch”. This makes it possible to switch larger loads with small ones. This can be really useful, for example, if a larger relay, motor or lightbulb needs to be switched with an Arduino board.

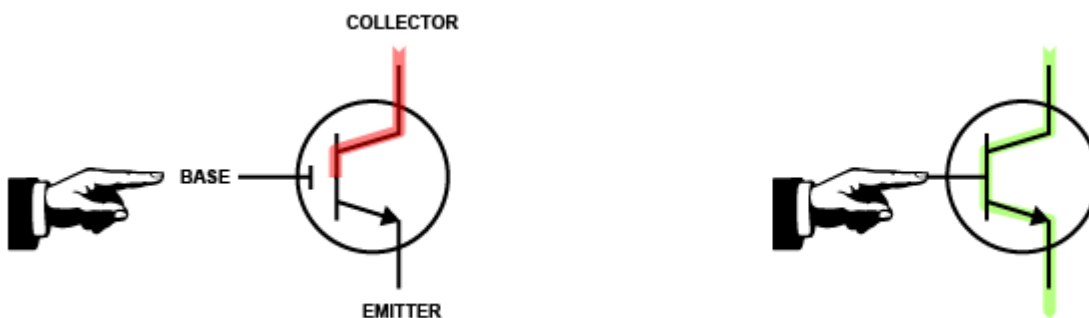

You can imagine the transistor like a switch. When the switch is pressed, the current flows. If the switch is released, the current no longer flows. The transistor has three connections: Base, Emitter and Collector. The voltage at the base-emitter switches the collector-emitter path. The circuit of a transistor depends on its type. There are two main types of transistors: NPN and PNP transistors. The current direction (collector-emitter) must be observed, otherwise, the transistor could be damaged. We will use NPN transistor most of the time.

Here is a drawing from the [datasheet](#) of the TIP 122, which shows where base, emitter and collector pins can be found.

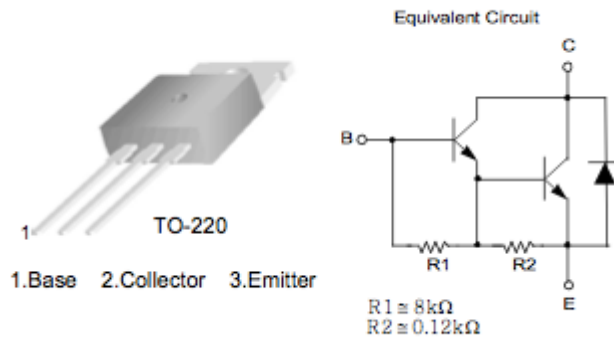

The following diagram visualizes the current flow (I/red) and the voltage flow (U/blue) which are applied to the transistor. Important: A base resistor (RB) and a load are always required for correct operation.

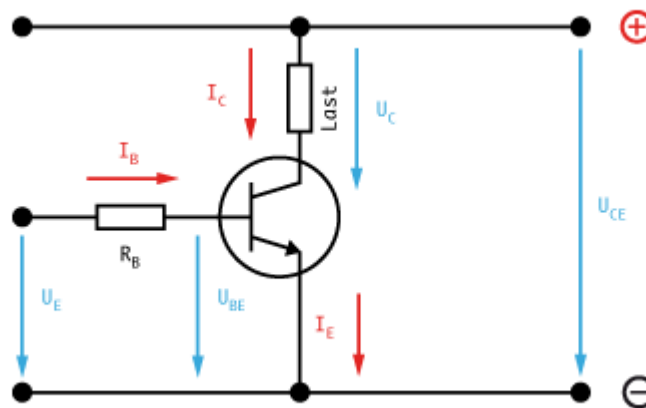

- UCE = Kollektor-Emitter-Voltage
- UE = Driving Voltage
- UBE = Base-Emitter-Voltage (Threshold value)
- IC = Collector Current
- IB = Base current
- RB = Base resistor

The Transistor as a Switch

A common use of a transistor is in the switching of higher loads - since most microcontrollers are limited in their output power on digital pins. For example, the Arduino can switch a load of 5V at 20mA per output. This is enough for LED's and maybe a small vibration motor. However, if a fan, a high power LED, a solenoid, a motor, etc. is connected you definitely need a transistor circuit. In this case, the transistor works similar to a relay: it switches higher loads with smaller loads. A distinction must also be made between switching non-inductive loads (e.g. LED) and inductive loads (e.g. fan, relay, motor). An inductive load will probably need a Fly Back Diode.

Switching a non-inductive Load

For switching a non-inductive load, the transistor circuit is very simple to set up. You only need an NPN transistor (TIP 122) and a series resistor in the path IB (1 kOhm). The circuit diagram looks as follows:

R1 = 1 kOhm (approximate value)

Transistor = TIP 122

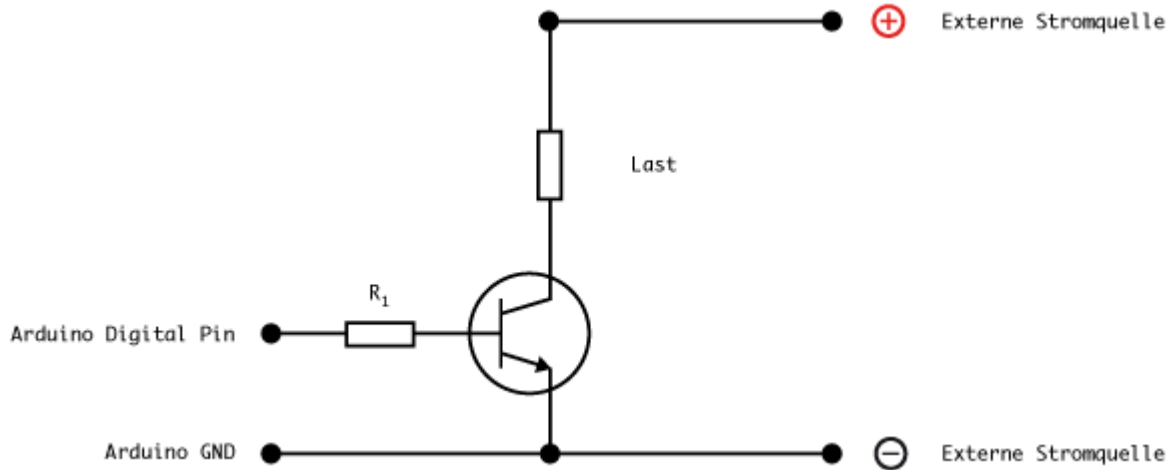

Example

In this example, we want to light up the RGB LED strip and control its brightness. According to the labelling and datasheet, the strip needs 12V supply voltage - corresponding resistors are already present and soldered on the strip. To realize this circuit we need a 12V power supply, one transistor (TIP 122 NPN) per channel, one resistor (1kOhm) per channel and the Arduino.

The following setup is needed to control a single color (here red)...

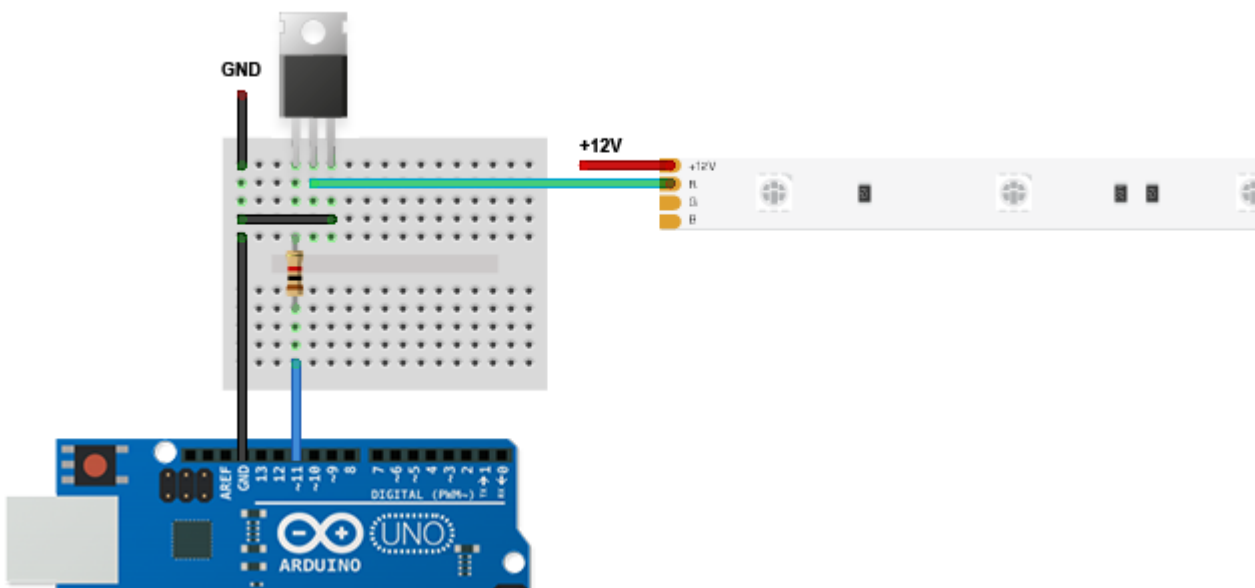

We program the Arduino with the following example code, which fades the red channel back and

forth.

```
#define RED_LED 10 // PWM PIN
void setup()
{
  pinMode(RED_LED, OUTPUT);
}
void loop()
{
  for (int i = 0; i < 255; i++)
  {
    analogWrite(RED_LED, i);
    delay(10);
  }
  for (int i = 255; i > 0; i--)
  {
    analogWrite(RED_LED, i);
    delay(10);
  }
}
```

Exercise 1

1. Extend the previously developed circuit so that all three channels of the RGB LED strip can be controlled differently.
2. Program a colour change that fades between red, green and blue (logic: off>red>green>blue>off).

Solution Exercise 1.2

```
const int RED_LED = 11; // PWM Pin
const int GRN_LED = 10; // PWM PIN
const int BLU_LED = 9; // PWM PIN

void setup()
{
  pinMode(RED_LED, OUTPUT);
  pinMode(GRN_LED, OUTPUT);
  pinMode(BLU_LED, OUTPUT);
}
void loop()
{
  for (int i = 0; i < 255; i++)
  {
    analogWrite(RED_LED, i);
    delay(10);
  }
}
```

```
for (int i = 255; i > 0; i--)
{
  analogWrite(RED_LED, i); // D
  analogWrite(GRN_LED, (-1) * (255 - i));
  delay(10);
}
for (int i = 255; i > 0; i--)
{
  analogWrite(GRN_LED, i);
  analogWrite(BLU_LED, (-1) * (255 - i));
  delay(10);
}
for (int i = 255; i > 0; i--)
{
  analogWrite(BLU_LED, i);
  delay(10);
}
}
```

Exercise 2

Develop the circuit as shown.

Add in a potentiometer and write new code to control the motor speed by rotating a potentiometer.



The diode in the picture is called a **flyback diode** (also known as a freewheeling diode) and it's crucial when controlling motors or any inductive load with a transistor.

Any time you switch a motor or relay with a transistor, add a flyback diode across it.



When you suddenly turn off a motor (by turning the transistor off), the current through the motor's coil is interrupted. Because the coil stores energy in a magnetic field, that field collapses and generates a high voltage spike across the motor that flows back to the circuit and can potentially damage the Arduino.

The flyback diode is connected in reverse across the motor (cathode to positive, anode to ground). During normal operation, it doesn't conduct and has no effect on the circuit. But when the motor is switched off and generates that reverse voltage spike, the diode becomes forward-biased (active) and

provides a safe path for that energy to dissipate harmlessly through the motor and diode itself, protecting your components.

You can see the diode placed across the motor terminals with a specific orientation - the stripe (cathode) points toward the positive voltage supply. This is critical, if you put it backward, it will short circuit your power supply when the motor is on.

Further information

[Controlling Motors with Transistors](#)

[Make Presents: The Transistor](#)

[Bipolarer Transistor](#)

[Der Transistor als Schalter](#)

From:
<https://wiki.zhdk.ch/iad/> - **IAD Wiki**

Permanent link:
https://wiki.zhdk.ch/iad/doku.php?id=electrical_engineering:transistors_as_switches&rev=1767952880

Last update: **2026/01/09 11:01**

